

CROSS-LINK[®]

PROTECTOR BRIDGE

HEAVY DUTY PROTECTOR BRIDGES

U.S. PATENT No: 6,747,212

CROSS-LINK[®] Protector Bridges are designed to utilize the space between multiple parallel cable protector runs. These bridges provide additional cable channels while providing a continuous, level crossing surface for vehicle and pedestrian traffic.

MODEL	DESCRIPTION	COLOR	A LENGTH	B WIDTH	C HEIGHT	D-CHAN. WIDTH	E-CHAN. HEIGHT	WEIGHT
-------	-------------	-------	-------------	------------	-------------	------------------	-------------------	--------

BRIDGE FOR LINEBACKER HD 4 AND 5 CHANNEL

CL2X150-4/5	Bridge for Linebacker CP5X125 or CP4X125	Orange	36 in. (914.4 mm)	14 in. (355.6 mm)	2.125 in. (53.0 mm)	1.5 in. (38.1 mm)	1.5 in. (38.1 mm)	18 lbs. (8.2 kg)
-------------	--	--------	----------------------	----------------------	------------------------	----------------------	----------------------	---------------------

BRIDGE FOR LINEBACKER GP 5 CHANNEL

CL2X150-5GP	Bridge for Linebacker CP5X125-GP	Orange	36 in. (914.4 mm)	12.5 in. (317.5 mm)	1.875 in. (47.6 mm)	1.5 in. (38.1 mm)	1.5 in. (38.1 mm)	14 lbs. (6.4 kg)
-------------	----------------------------------	--------	----------------------	------------------------	------------------------	----------------------	----------------------	---------------------

BRIDGE FOR GUARD DOG 5 CHANNEL

CL2X150-5GD	Bridge for Guard Dog GD5X125	Orange or Black	36 in. (914.4 mm)	13 in. (330.2 mm)	2.0 in. (50.8 mm)	1.5 in. (38.1 mm)	1.5 in. (38.1 mm)	16 lbs. (7.3 kg)
-------------	------------------------------	-----------------	----------------------	----------------------	----------------------	----------------------	----------------------	---------------------

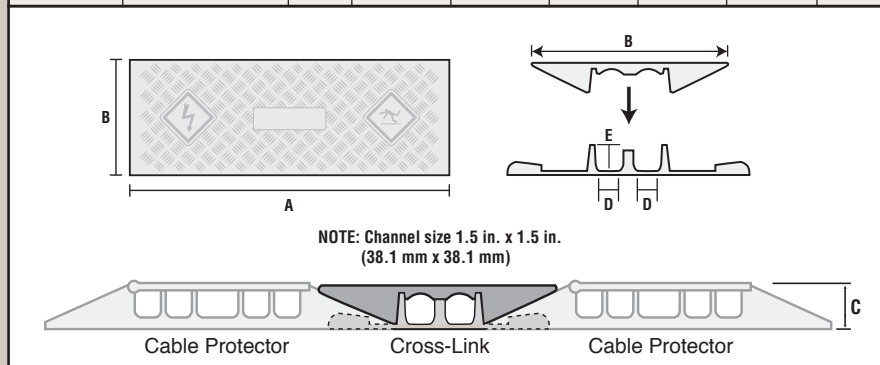

SPECIFICATION DATA		LOAD CAPACITY PER TIRE/AXLE		Safety Warning Symbols Molded into Protector
Material.....	Polyurethane (UV stabilized)	Channels	Max Load 70°F (21°C)	
Operating Temp.....	-40°F to 120°F (-40°C to 48°C)	2.....	10,500 lbs./Tire (4,763 kg)	
Safety Symbols.....	Per ANSI. Z535.3-1991		21,000 lbs./Axle (9,526 kg)	

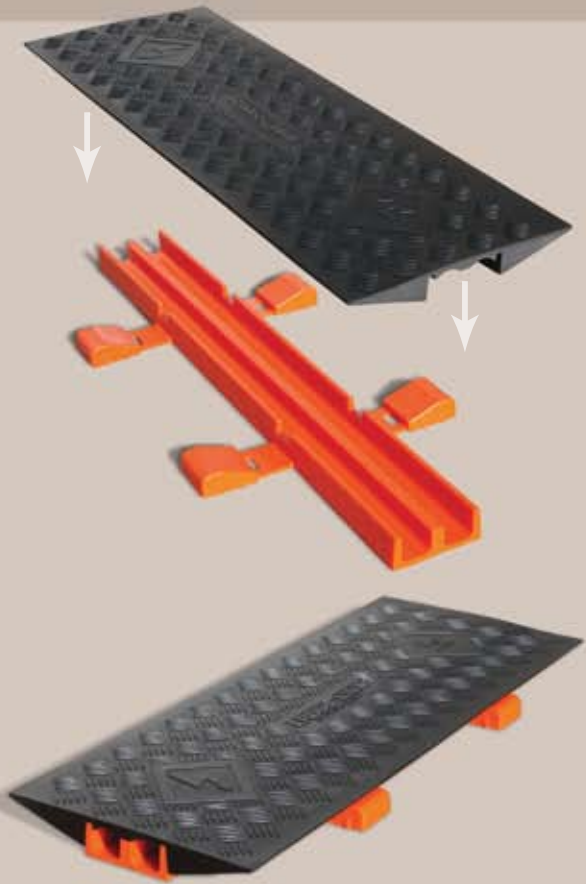

Cross-Link[®] with Guard Dog[®] 5 Channel Cable Protectors



Cross-Link[®] with Guard Dog[®] 5 Channel Cable Protectors with End Caps

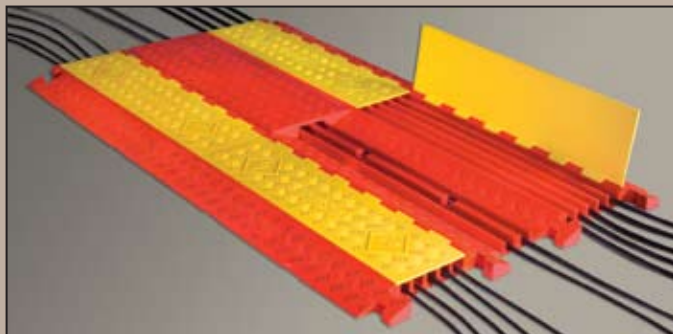

Cross-Link[®] with Linebacker[®] HD 5 Channel Cable Protectors



Cross-Link[®] with Guard Dog[®] 5 Channel Cable Protectors with End Caps and Cross-Guard[®] ADA Ramps